

H0420

Programmable MP3 Audio Player for Exhibitions and Kiosk Applications

Firmware Update: Version 1.5 Build 3806

[For upgrading to the new firmware, please see page 3 for the procedure.](#)

This document describes the changes since version 1.5 of the firmware (build 3806). If you want to review the changes from versions 1.0 to 1.4, please see the documents “h0420_3508.pdf”, “h0420_3444.pdf”, “h0420_3637.pdf” and “h0420_3665.pdf” respectively.

New functionality & modifications

1. “Hidden” FAT partitions on a CompactFlash card are now also accepted

For improved compatibility with Microsoft Windows and Linux, the H0420 now also recognizes partitions on the CompactFlash card where the “hidden” flag is set. The hidden flag is ignored (Microsoft Windows and Linux also ignore this flag).

2. Writing to CompactFlash card proceeds quicker

Depending on the brand of the CompactFlash card, writing data to the card (from the script in the H0420) was very slow. This has been improved by using an optimized sequence of CompactFlash commands.

3. New native function `strcpy()`

The new function `strcpy()` makes a duplicate of the input string: it copies a packed string into a packed string and an unpacked string into an unpacked string. To convert strings from packed to unpacked, or to make sure that the destination string is packed or unpacked regardless of the input string, use functions `strpack()` and `strunpack()`.

4. New native function `frename()`

The new function `frename()` lets you both rename files or move them to a different subdirectory (or both at the same time).

5. New native function `fstat()`

The new function `fstat()` returns the file size and the file time stamp. Although function `flength()` already existed to return the file size, now function to retrieve its time stamp was previously available.

6. New native function `cvttimestamp()`

The function `cvttimestamp()` converts a Unix time stamp value (i.e. the number of seconds since January 1, 1970) to day, month and year, and hours, minutes and seconds fields.

7. Graphic LCDs with KS0108 controllers are now supported

The firmware now also supports graphical LCDs and other displays with controllers that are compatible with the KS0108 controller.

8. New native function `image()` for graphic LCDs

The new function `image()` displays an image on an LCD (or other supported display). The LCD

must have graphic capabilities for this to work correctly. The bitmap to display must be in the "polyraster" format. See the CompuPhase web site for details.

9. Fix: fcreate() did not create new files in a subdirectory

The function `fcreate()` failed to create new files in a subdirectory of the CompactFlash card (overwriting existing files in a subdirectory worked, though). This has been corrected.

10. Fix: printf() did not accept %% to print a literal %

The function `printf()` did not allow printing the "%" character, which is a meta character for value substitution. This has been corrected.

11. Fix: on failure, play() function continued playing at zero volume

When function `play()` could not open the specified file and a track was already playing, it continued to play the current track, but at volume zero. The result is that `audiostat()` would return status `Playing`, but that you hear nothing. The firmware has been corrected such that `play()` now continues playing the current track at the current volume level.

12. Fix: the mp3loop did not disable the bit reservoir with the DLL encoder

The mp3loop utility for creating seamless looping MP3 tracks disabled the bit reservoir when the LAME encoder was used as a separate process, but not when using the DLL version of the LAME encoder. This has been fixed.

The function `fcreate()` failed to create new files in a subdirectory of the CompactFlash card (overwriting existing files in a subdirectory worked, though). This has been corrected.

13. Fix: modulo operator when the divisor is negative

According to the Pawn language rules, integer divisions should be floored (i.e. rounded to the lower value) and the remainder must be adjusted in accordance. The abstract machine rev. 3665 had a bug in this operation (for negative divisors). This has been corrected.

14. Fix: looping was not always "gapless"

On CompactFlash cards with a capacity of 1 GB or more, and slow reading speed, a gap was introduced on every loop of a track, even if the track was prepared for gapless looping. This has been corrected.

15. Fix: CompactFlash cards using version 3 of the spec. were rejected

The previous firmware accepted CompactFlash cards that adhered to versions 1 and 2 of the specification. Version 3 of the CompactFlash specification is not 100% backwards compatible, and these cards were rejected. The firmware has been made compatible with version 3 of the specification.

16. PAWN scripting language & tools

The compiler and toolkit have been improved in various areas, especially in the area of user-friendliness. The help system of the Quincy IDE has been revised, and the editor now has a tab to make working with multi-file projects easier. Errors and warnings are flagged with a different colour from standard messages, to make them stand out.

Upgrading the Firmware

When upgrading firmware, the scripts in the PAWN language should also be recompiled with the latest release of the PAWN compiler. Any “**amx**” file built for earlier versions of the firmware may not function accurately with the new firmware. The new release of the PAWN toolkit is included in each firmware update.

The procedure below describes how to upgrade the firmware using a PC running Microsoft Windows. When you do not run Microsoft Windows, please contact us for an alternative upgrade procedure.

We advise you to read through this procedure before starting the upgrade, so that you have a mental picture of the steps that are involved in the procedure.

1. Install the software

If you have not done so already, download the firmware update and then “open” or “run” the file. The firmware update file is a *setup* program that installs the required components. If you received the firmware update on CD-ROM, you can install it directly from the CD-ROM.

2. Connect the H0420 to a PC & remove the CompactFlash card

First unplug the H0420 MP3 player from the 5V power. Then remove the CompactFlash card from the H0420, and connect a standard RS232 cable (not a null-modem cable) between a PC and the H0420. Plug the power connector back into the H0420 once the serial cable is connected. Do not re-insert the CompactFlash card (this is done in step 5).

If you are using a simulated RS232 port (for example, through an USB-to-RS232 adapter), it is best to wait a few seconds between inserting the RS232 plug and the power plug —10 seconds should always be sufficient.

If the device was already connected to the PC through the RS232 cable and the CompactFlash card had already been removed, it is still advised to remove the power plug for a few seconds, so that the device does a full restart.

3. Run the “Firmware Update Tool”

Locate the “Firmware Update Tool” in the *Start Menu* (under *Programs / H0420 MP3 Controller*), and run it —this tool was installed in step 1. See the screen shot below for the appearance of the Firmware Update Tool.

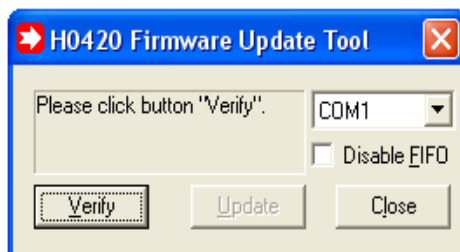

Make sure that the correct COM port (RS232) is selected in the update tool.

Some simulated RS232 ports (USB-to-RS232 adapters) do not properly simulate the RS232 FIFO buffers. For these devices, you may set a check-mark in the “Disable FIFO” option.

4. First click “Verify”, then click “Update”

Click on the button “Verify” and allow it to complete. This function checks the current firmware version and the device model and reports these to you. If all is well, it will tell you the version number of the firmware that is currently in the H0420, as well as the version number of the latest firmware. If the device already has the latest firmware, this tool will tell you so.

If the "Verify" button found no error, you can click on the button "Update". Updating the firmware may take a minute. Do not abort the program while the firmware update is processing.

After the update has completed, the program will inform you that the device will automatically reset itself after a time-out of a few seconds. If you wish to check that the firmware has indeed been uploaded correctly, you will have to wait at least this number of seconds before clicking on the button "Verify".

5. Recompile the PAWN script

Although any existing script on the CompactFlash card will still run, it is advised to recompile the source code of the script with the updated PAWN compiler. After compiling the script and storing the resulting file AUTORUN.AMX on the CompactFlash card, you can now re-insert the CompactFlash card in the H0420 player.

Trouble shooting — when uploading fails

If the “Verify” button times out and responds with the error message:

Unable to synchronize with the device.

Please check the serial connection.

- check the RS232 cabling
- “power cycle” the H0420 MP3 player (remove the power plug from the device for a few seconds and then re-insert it)
- run the update procedure (on the previous page) again.

If this fails again, try to reset the H0420 while the Update Tool is busy verifying the device. That is: click on the button “Verify” and then press the “**RESET**” switch on the H0420. See below for the location of the reset button. You may also want to try to perform the procedure after rebooting the PC, or from a different PC.

If all fails, a last option that you can try is to set the H0420 in “Boot Loader mode” (see below), and run the procedure again. In this case, the “Verify” button will inform you that it cannot find the “current” version of the firmware in the H0420, but it still allows you to update to the latest revision. Resetting the H0420 to Boot Loader mode is typically necessary when an earlier upload has been aborted or interrupted.

Resetting the H0420 to “Boot Loader mode”

The H0420 has two switches, behind the connector of the RS232. In order to gain access to these switches, it may be necessary that you open the case in which the H0420 is mounted.

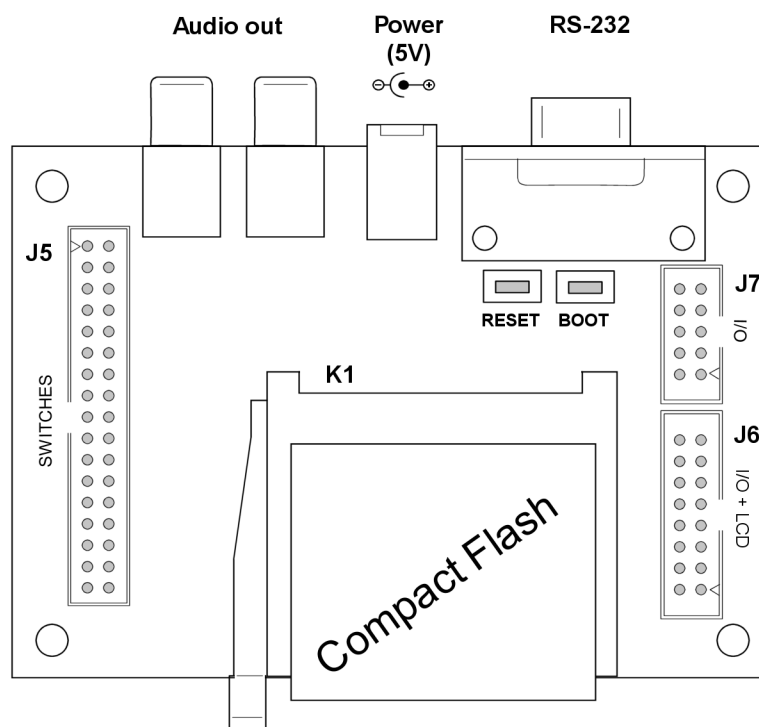

These switches must be pressed and released in the correct order:

- Press (and hold) “**RESET**”
- Press (and hold) “**BOOT**”
- Release “**RESET**”
- Release “**BOOT**”

It is advised to “power cycle” the device before resetting it to boot loader mode, and to remove the CompactFlash card. (Do *not* power-cycle the device *after* switching it to boot loader mode, because this would reset the device to normal mode.)