

H0420

Programmable MP3 Audio Player for Exhibitions and Kiosk Applications

Firmware Update: Version 1.6 Build 3950

[For upgrading to the new firmware, please see page 4 for the procedure.](#)

This document describes the changes since version 1.6 of the firmware (build 3950). If you want to review the changes from versions 1.0 to 1.5, please see the documents “h0420_3508.pdf”, “h0420_3444.pdf”, “h0420_3637.pdf”, “h0420_3665.pdf” and “h0420_3806.pdf” respectively.

The revision with build number 3950 corrects a few issues in version 1.6 with build number 3934. These issues are:

1. When stopping a track (function `stop()`), the queue of the MP3 decoder still contained a fraction of a second of audio. This fraction was prefixed to the next track. Build 3950 corrects this problem.
2. The PAWN compiler did not accept strings that ended with a double backslash.

New functionality & modifications

1. Support for a network extension board with TCP/IP stack

Two new extension boards are available for the H0420: the H0415E and the H0416E. Both these boards are network extension boards with an Ethernet hardware interface and a TCP/IP protocol stack. (The differences between the boards are mostly the shape/size and the positioning of the network connector.)

The network extension allows to add functionality like audio streaming, updating audio tracks or configuration files over the network, and remote monitoring and control.

2. Code Overlays in PAWN script

With the new code overlay system, scripts are no longer limited in size by the amount of RAM available.

3. File writing is faster

The performance of writing data to the CompactFlash card was improved again, especially on large files.

4. Ability to encrypt the entire CompactFlash card

Next to the support of playing encrypted tracks, the H0420 now also supports CompactFlash cards with encrypted partitions. On an encrypted CompactFlash card, the content of all files is encrypted, including the content of the directory structure (so the filenames are hidden too).

A new utility is provided to “lock” an entire CompactFlash card.

5. Support for Noritake graphical VFDs

In addition to the character LCDs and the graphical LCDs based on the KS0108 controller (or compatibles), the H0420 now also supports graphical VFDs (Vacuum Fluorescent Display) from the Noritake GU-7800 series (e.g. Noritake GU140x16-7806A).

6. New public function @eject()

This function is called when removing the CompactFlash card from the H0420. Note that you

cannot access the card at the time of call (so not track playing either). Also note that the H0420 resets roughly 1 second after detecting a card eject, so the `@eject()` function must be quick.

7. New native function version()

This new function returns the major and minor version numbers, and the build number of the firmware. This allows you to write a script that supports multiple versions of the firmware.

8. Native function play() now also accepts a "resource id" of a file

A resource id consists of the "inode number" and the size of the file. This is shorter than a complete path/filename, and it also avoids the seek time through the directory structure. As explained in the manual, you can use the native function `fstat()` to obtain a resource id from a file.

9. New native functions readconfig() and storeconfig() allow to store configuration data in Flash ROM

These new functions can save (and read back) a small amount of data on the H0420 board itself. This allows data to be saved even if the CompactFlash card is removed.

10. New native function filecrc()

This function calculates the 32-bit CRC of a file. The purpose is to verify the files integrity or to detect changes of the file without needing to compare the file with a backup copy. The `filecrc()` function uses same algorithm as SFV and WinZip.

11. New native function fattrib() sets the attributes and the date/time stamp of a file

As a complement to function `fstat()`, this new function allows to change the file attributes and/or the file's date and time.

12. Native function fstat() now also returns the file attributes and "inode" number

Native function `fstat()` was extended to return more information of a file: its attributes (such as "read-only", "hidden" and "modified") and its "inode number" (an inode number uniquely represents a file on a physical medium).

13. Fix: an audible "click" at the end of an aborted track has been removed

When aborting a track with function `stop()` (or by playing a new track, which does an implicit stop), there was a soft, but yet audible click. This was due to the way that the MP3 decoding engine was reset. The improved implementation in this release avoids the click.

14. Fix: settimestamp() did not take 29th february into account if the current year is a leap year

Function `settimestamp()` handled past leap years when converting a time stamp to a date, but it did not handle the case where the *current* year is a leap year. This has been corrected.

15. Fix: SYLT events would still fire at their pre-set time when the track was paused (or stopped)

The "synchronized lyrics" feature is based on a timer that runs synchronously with the MP3 track. However, when the track was paused, this timer continued to run. This has been corrected.

16.Fix: sleep instruction was not functional

The “sleep” instruction caused a reset or a script abort. This has been corrected.

17.PAWN scripting language & tools

The compiler and toolkit have been improved again in various areas. The compiler generates tighter code. The Quincy IDE can load and save “work spaces” where a work space is a collection of files that form a project, plus any specific build options. Syntax highlighting in Quincy is improved as well.

Upgrading the Firmware

When upgrading firmware, the scripts in the PAWN language should also be recompiled with the latest release of the PAWN compiler. Any “**amx**” file built for earlier versions of the firmware may not function accurately with the new firmware. The new release of the PAWN toolkit is included in each firmware update.

The procedure below describes how to upgrade the firmware using a PC running Microsoft Windows. When you do not run Microsoft Windows, please contact us for an alternative upgrade procedure.

We advise you to read through this procedure before starting the upgrade, so that you have a mental picture of the steps that are involved in the procedure.

1. Install the software

If you have not done so already, download the firmware update and then “open” or “run” the file. The firmware update file is a *setup* program that installs the required components. If you received the firmware update on CD-ROM, you can install it directly from the CD-ROM.

2. Connect the H0420 to a PC & remove the CompactFlash card

First unplug the H0420 MP3 player from the 5V power. Then remove the CompactFlash card from the H0420, and connect a standard RS232 cable (not a null-modem cable) between a PC and the H0420. Plug the power connector back into the H0420 once the serial cable is connected. Do not re-insert the CompactFlash card (this is done in step 5).

If you are using a simulated RS232 port (for example, through an USB-to-RS232 adapter), it is best to wait a few seconds between inserting the RS232 plug and the power plug —10 seconds should always be sufficient. Note that “simulated RS232” is less reliable than hardware RS232; it is advised to use a real RS232 port for the firmware update.

If the device was already connected to the PC through the RS232 cable and the CompactFlash card had already been removed, it is still advised to remove the power plug for a few seconds, so that the device does a full restart.

3. Run the “Firmware Update Tool”

Locate the “Firmware Update Tool” in the *Start Menu* (under *Programs / H0420 MP3 Controller*), and run it —this tool was installed in step 1. See the screen shot below for the appearance of the Firmware Update Tool.

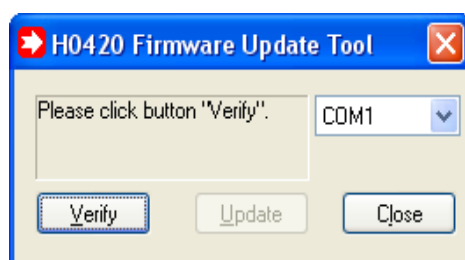

Make sure that the correct COM port (RS232) is selected in the update tool.

If you have a custom key file (for encrypted MP3 tracks or encrypted CompactFlash cards), or if you have an Ethernet extension board for the H0420, the Firmware Update Tool shows up to two additional rows with entry fields: one for the MAC address and one key file. The field for the MAC address is initially empty —it is updated when you click on the button “Verify”. The field for the key file may contain the path to a key file, if one was found in the program directory.

4. First click “Verify”, then click “Update”

Click on the button “Verify” and allow it to complete. This function checks the current firmware version and the device model and reports these to you. If all is well, it will tell you the version number of the firmware that is currently in the H0420, as well as the version number of the latest firmware. If the device already has the latest firmware, this tool will tell you so.

If you have a H0420 board with Ethernet extension, clicking the “Verify” button will also have updated the MAC address field with the address that is currently in the device. Unless you want to assign a different address, there is no need to change it.

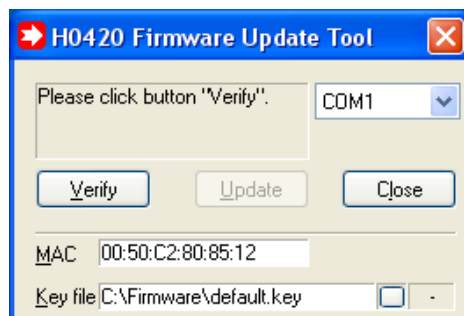

If the “Verify” button found no error, you can click on the button “Update”. Updating the firmware may take a minute. Do not abort the program while the firmware update is processing.

After the update has completed, the program will inform you that the device will automatically reset itself after a time-out of a few seconds. If you wish to check that the firmware has indeed been uploaded correctly, you will have to wait at least this number of seconds before clicking on the button “Verify” again.

5. Recompile the PAWN script

Although any existing script on the CompactFlash card will still run, it is advised to recompile the source code of the script with the updated PAWN compiler. After compiling the script and storing the resulting file AUTORUN.AMX on the CompactFlash card, you can now re-insert the CompactFlash card in the H0420 player.

Trouble shooting — when uploading fails

If the “Verify” button times out and responds with the error message:

Unable to synchronize with the device.

Please check the serial connection.

- check the RS232 cabling
- “power cycle” the H0420 MP3 player (remove the power plug from the device for a few seconds and then re-insert it)
- run the update procedure (on the previous page) again.

If this fails again, try to reset the H0420 while the Update Tool is busy verifying the device. That is: click on the button “Verify” and then press the “**RESET**” switch on the H0420. See below for the location of the reset button. You may also want to try to perform the procedure after rebooting the PC, or from a different PC.

If all fails, a last option that you can try is to set the H0420 in “Boot Loader mode” (see below), and run the procedure again. In this case, the “Verify” button will inform you that it cannot find the “current” version of the firmware in the H0420, but it still allows you to update to the latest revision. Resetting the H0420 to Boot Loader mode is typically necessary when an earlier upload has been aborted or interrupted.

Resetting the H0420 to “Boot Loader mode”

The H0420 has two switches, behind the connector of the RS232. In order to gain access to these switches, it may be necessary that you open the case in which the H0420 is mounted.

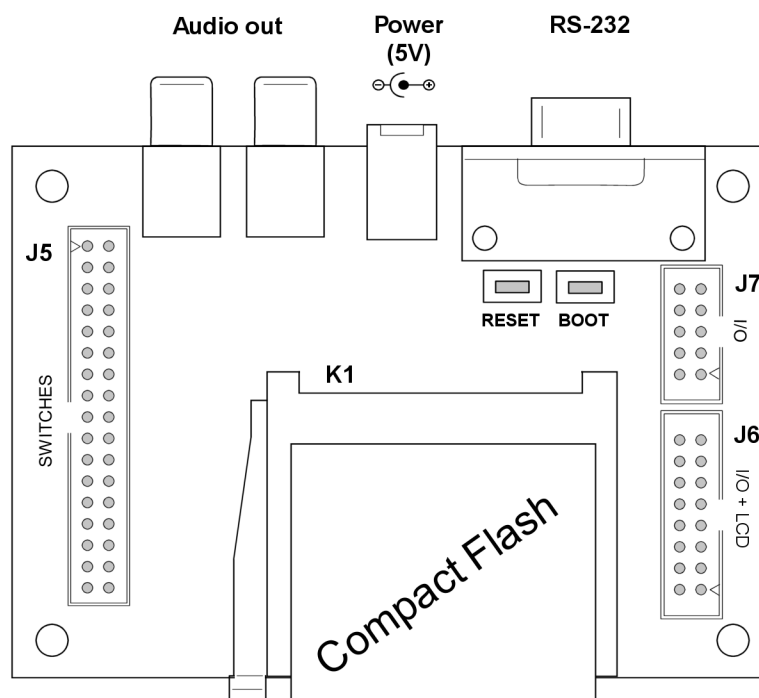

These switches must be pressed and released in the correct order:

- Press (and hold) “**RESET**”
- Press (and hold) “**BOOT**”
- Release “**RESET**”
- Release “**BOOT**”

It is advised to “power cycle” the device before resetting it to boot loader mode, and to remove the CompactFlash card. (Do *not* power-cycle the device *after* switching it to boot loader mode, because this would reset the device to normal mode.)