

H0420

Programmable MP3-player for scale models, broadcast systems and special applications

Firmware Update: Version 1.7 Build 4045

[For upgrading to the new firmware, please see page 4 for the procedure.](#)

This document describes the changes since version 1.7 of the firmware (build 4045). If you want to review the changes from versions 1.0 to 1.6, please see the documents “h0420_3508.pdf”, “h0420_3444.pdf”, “h0420_3637.pdf”, “h0420_3665.pdf”, “h0420_3806.pdf” and “h0420_3950.pdf” respectively.

New basic functionality & modifications

1. New public function @quickreset()

@quickreset() is an alternative for @reset(). If the script contains @quickreset() and no debug information is present in the script, the wait for debugger is skipped. The result is that the start-up delay of the H0420 is reduced by two seconds. Note that you cannot connect to the H0420 with FileLink or the Pawn debugger if the script contains @quickreset(), because @quickreset() disables the debugger hook checking (FileLink also uses the debugger hook to connect to the H0420).

2. Functions to read and write INI files

The firmware now supports the following new native functions readcfg(), readcfgvalue(), writecfg(), writecfgvalue() and deletecfg(). These functions make it easy to keep settings in a configuration file that has the syntax of INI files.

3. fexist() and fmatch() also match directories

Previously, only files were matched, so you could never list directories. Use native function fstat() to tell a file from a directory.

4. @eject() no longer has a time limit

Previously, the function @eject() could only perform actions that executed quickly, because the auto-reset of the device was already in progress. In this new release, the auto-reset will only start after @eject() has executed. If no @eject() function is present, the device will still auto-reset without delay.

5. Any script name is now allowed

The restriction that a script must be called “autorun.amx” has been lifted. If there is only a single script, it can have any name (as long as the extension is “.amx”). If there are multiple script files, one of these should be called autorun.amx (this one will then run).

6. Function wavegenerator() now also has a “bit stream” wave type

The bit-stream wave type allows you to create a serial protocol on I/O pin 16 (output). A burst of up to 32 bits can be sent at an arbitrary frequency.

7. Correction and behaviour modification of fexist() and fmatch()

The functions fexist() and fmatch() allow a file pattern as a parameter. The validity of the file pattern is now checked, and if the parameter does is not a valid pattern, the functions assume that

it is a literal filename. This behaviour change is especially useful for `fxist()`, because some of the special characters for a pattern are also valid characters for filename (for example, the characters “[“ and “]” are used to denote a character range in a pattern, but you may also use them in a filename).

8. Correction: function `setiopin()` of pin 16 had insufficient range

The range was documented as 0...1023, but the player only accepted 0...255; In addition, the output range was 0V...1.2V instead of 0V...4.8 V. This has been corrected.

9. Correction: an audible click under rare circumstances

Depending on physical location of the track on the CompactFlash card, there could be an audible click between two tracks. This has been corrected.

10. Correction: creating a file in the root directory failed in the path root was specified

An attempt to create a file in the root directory failed if the path name included the slash or backslash character. For example, creating a file called “test.log” would succeed, but creating “/test.log” would fail because of the initial slash. This has been corrected.

11. Correction: standby mode failed to properly resume

The `standby()` function puts the H0420 board in low-power mode. It was found that on many boards, due to a timing issue, the MP3 decoder was not properly reinitialized after resume from standby. This has been corrected.

12. PAWN scripting language & tools

The compiler and toolkit have been improved again in various areas, especially error checking. The Quincy IDE has tooltip help for known (native and public) functions and support for code snippets to help writing code quicker. The FileLink utility now supports drag-&-drop with Windows explorer.

New functionality & modifications for the network extension

13. FTP server

A script can now enable an embedded FTP server. All logins and file transfers are handled via the public function `@nettransfer()`. Only one connection is allowed at this time. Both active and passive FTP are supported.

14. Native functions `play()` and `netstream()` accept a file URL

The functions `play()` and `netstream()` support streaming from a file on a web server. This means that it is no longer necessary to set up a stream server (Shoutcast, Icecast) to stream MP3 tracks; it is sufficient to place the MP3 tracks on a web server.

15. New native function `netsnmpcfg()`

The new function `netsnmpcfg()` sets the “community strings” for the read-only and read-write communities. This is SNMP terminology for setting one password for read access and another password for read/write access.

16.Function netstream() has an extra parameter: autoplay

By default, the native function `netstream()` starts playing the stream as soon as the buffer mark is reached. Starting with this revision of the firmware, this automatic playing can be disabled. One use for not automatically playing the stream is to verify whether the stream is stable, while playing music from the CompactFlash card and switch to the stream only after it has been deemed “stable”.

17.New native functions neturlencode() and neturldecode()

The new function `neturlencode()` transforms a string to URL-encoding (or URI-encoding) and the function `neturldecode()` does the reverse transformation. URL encoding is needed when names of files to download (or to stream) contain spaces or special characters.

18.Various improvements in HTTP streaming

HTTP streaming is now compatible with more streaming servers and more configurations (buffer size, burst size, etc.) of these servers. Servers with metadata intervals of 32 kiB or higher are now also supported. Especially servers that stream at a high bitrate use large metadata intervals.

19.Miscellaneous corrections and improvements in network support

Handling larger packets and handling quick bursts of (outgoing) packets have been improved and corrected. A correction in the UDP protocol improved compatibility with a number of higher-level protocols that are based on UDP, such as SNMP and DNS.

Upgrading the Firmware

When upgrading firmware, the scripts in the PAWN language should also be recompiled with the latest release of the PAWN compiler. Any “**amx**” file built for earlier versions of the firmware may not function accurately with the new firmware. The new release of the PAWN toolkit is included in each firmware update.

The procedure below describes how to upgrade the firmware using a PC running Microsoft Windows. When you do not run Microsoft Windows, please contact us for an alternative upgrade procedure.

We advise you to read through this procedure before starting the upgrade, so that you have a mental picture of the steps that are involved in the procedure.

1. Install the software

If you have not done so already, download the firmware update and then “open” or “run” the file. The firmware update file is a *setup* program that installs the required components. If you received the firmware update on CD-ROM, you can install it directly from the CD-ROM.

2. Connect the H0420 to a PC & remove the CompactFlash card

First unplug the H0420 MP3 player from the 5V power. Then remove the CompactFlash card from the H0420, and connect a standard RS232 cable (not a null-modem cable) between a PC and the H0420. Plug the power connector back into the H0420 once the serial cable is connected. Do not re-insert the CompactFlash card (this is done in step 5).

If you are using a simulated RS232 port (for example, through an USB-to-RS232 adapter), it is best to wait a few seconds between inserting the RS232 plug and the power plug —10 seconds should always be sufficient. Note that “simulated RS232” is less reliable than hardware RS232; it is advised to use a real RS232 port for the firmware update.

If the device was already connected to the PC through the RS232 cable and the CompactFlash card had already been removed, it is still advised to remove the power plug for a few seconds, so that the device does a full restart.

3. Run the “Firmware Update Tool”

Locate the “Firmware Update Tool” in the *Start Menu* (under *Programs / H0420 MP3 Controller*), and run it —this tool was installed in step 1. See the screen shot below for the appearance of the Firmware Update Tool.

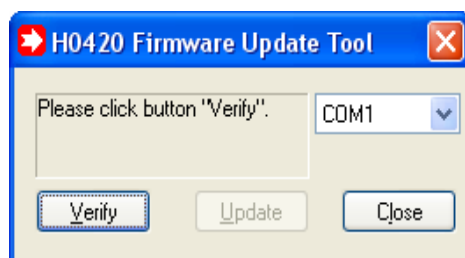

Make sure that the correct COM port (RS232) is selected in the update tool.

If you have a custom key file (for encrypted MP3 tracks or encrypted CompactFlash cards), or if you have an Ethernet extension board for the H0420, the Firmware Update Tool shows up to two additional rows with entry fields: one for the MAC address and one key file. The field for the MAC address is initially empty —it is updated when you click on the button “Verify”. The field for the key file may contain the path to a key file, if one was found in the program directory.

4. First click “Verify”, then click “Update”

Click on the button “Verify” and allow it to complete. This function checks the current firmware version and the device model and reports these to you. If all is well, it will tell you the version number of the firmware that is currently in the H0420, as well as the version number of the latest firmware. If the device already has the latest firmware, this tool will tell you so.

If you have a H0420 board with Ethernet extension, clicking the “Verify” button will also have updated the MAC address field with the address that is currently in the device. Unless you want to assign a different address, there is no need to change it.

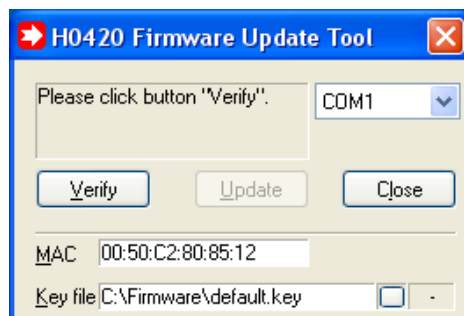

If the “Verify” button found no error, you can click on the button “Update”. Updating the firmware may take a minute. Do not abort the program while the firmware update is processing.

After the update has completed, the program will inform you that the device will automatically reset itself after a time-out of a few seconds. If you wish to check that the firmware has indeed been uploaded correctly, you will have to wait at least this number of seconds before clicking on the button “Verify” again.

5. Recompile the PAWN script

Although any existing script on the CompactFlash card will still run, it is advised to recompile the source code of the script with the updated PAWN compiler. After compiling the script and storing the resulting file AUTORUN.AMX on the CompactFlash card, you can now re-insert the CompactFlash card in the H0420 player.

Trouble shooting — when uploading fails

If the “Verify” button times out and responds with the error message:

Unable to synchronize with the device.

Please check the serial connection.

- check the RS232 cabling
- “power cycle” the H0420 MP3 player (remove the power plug from the device for a few seconds and then re-insert it)
- run the update procedure (on the previous page) again.

If this fails again, try to reset the H0420 while the Update Tool is busy verifying the device. That is: click on the button “Verify” and then press the “**RESET**” switch on the H0420. See below for the location of the reset button. You may also want to try to perform the procedure after rebooting the PC, or from a different PC.

If all fails, a last option that you can try is to set the H0420 in “Boot Loader mode” (see below), and run the procedure again. In this case, the “Verify” button will inform you that it cannot find the “current” version of the firmware in the H0420, but it still allows you to update to the latest revision. Resetting the H0420 to Boot Loader mode is typically necessary when an earlier upload has been aborted or interrupted.

Resetting the H0420 to “Boot Loader mode”

The H0420 has two switches, behind the connector of the RS232. In order to gain access to these switches, it may be necessary that you open the case in which the H0420 is mounted.

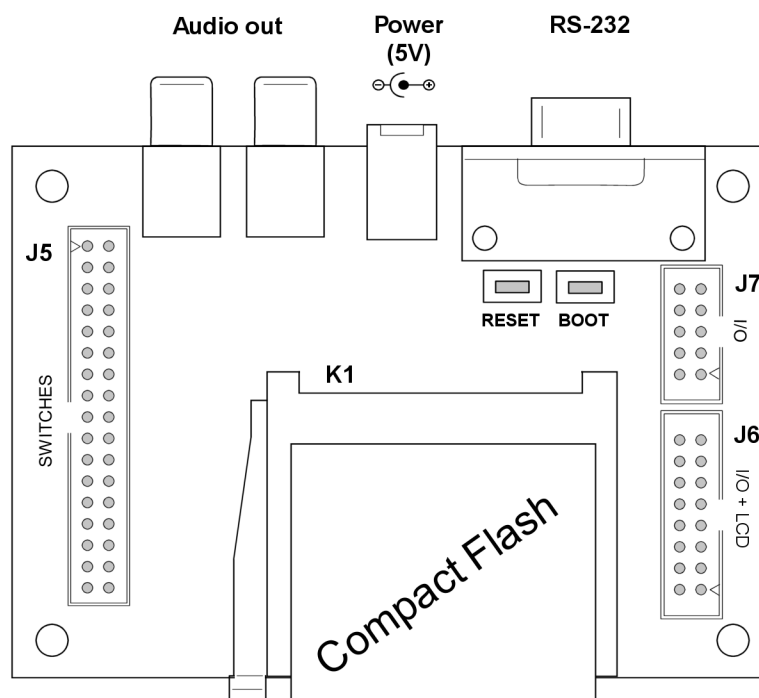

These switches must be pressed and released in the correct order:

- Press (and hold) “**RESET**”
- Press (and hold) “**BOOT**”
- Release “**RESET**”
- Release “**BOOT**”

It is advised to “power cycle” the device before resetting it to boot loader mode, and to remove the CompactFlash card. (Do *not* power-cycle the device *after* switching it to boot loader mode, because this would reset the device to normal mode.)